



# CONSTRUCTION SOLUTIONS SYSTEMS FOR NEW BUILD BRIDGES AND REFURBISHMENT PROJECTS

BUILDING TRUST





# SIKA – YOUR PARTNER

Throughout history, bridges have always been important, valuable structures in their own right. As part of our infrastructure, they allow faster and easier communication and transportation for people, livestock and merchandise. Thus, by their very nature, bridges are built in a variety of areas where the topography, ground conditions, or other existing structures and developments signify locations not otherwise suitable for conventional pathways, roads or railway construction. Therefore, bridges are found in the most challenging, exposed environments – crossing ravines, around mountains, over valleys, lakes, rivers, seas or other urban buildings and structures. Due to the apparent increase in traffic frequency and design loads across our bridge structures, additional stresses and strains are constantly being imposed on them. Modern bridges are predominantly built in reinforced concrete and designed with a service life-span of more than 100 years. Recent surveys in Europe and North America have shown that the majority of existing bridges already exhibit significant degrees of degradation. Many of them are therefore in need of substantial and often urgent repair and refurbishment.

# CONTENT

<b>04</b>	Quick Sika Solution – Navigation Guide by Bridge Type
<b>06</b>	Case Studies
<b>10</b>	Bridge Design Considerations for Cost Effective, Long Lasting and Sustainable Solutions
<b>12</b>	Bridge Exposures
<b>14</b>	An Overview of Damage and Deterioration – The Root Causes
<b>16</b>	General Bridge Considerations
<b>17</b>	General Bridge Refurbishment Procedures
<b>18</b>	Sika's Life Cycle Assessment Approach
<b>19</b>	Sustainable Concrete Protection
<b>22</b>	Sika – Your Complete System Supplier
<b>24</b>	An Overview of Sika Solutions for Bridges
<b>26</b>	Sika Solutions for Concrete Technology Sika Solutions for Concrete Repairs Sika Solutions for Structural Strengthening Sika Solutions for Bridge Deck Protection Sika Solutions for Waterproofing Sika Solutions for Concrete Protection Sika Solutions for Grouting and Fixing Sika Solutions for Steel Corrosion Protection Sika Solutions for Structural Bonding Sika Solutions for Segmental Bridge Adhesive Sika Solutions for the Rehabilitation of Masonry or Wooden Bridges

# QUICK SIKA SOLUTION – NAVIGATION GUIDE

AN OVERVIEW OF DAMAGE AND  
DETERIORATION – ROOT CAUSES,  
PAGE 14 – 23

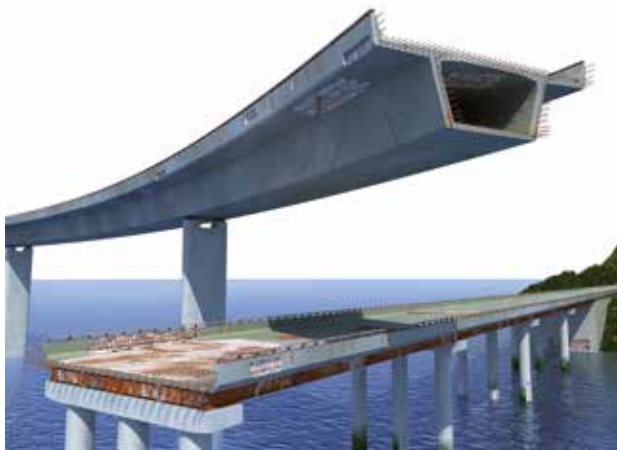

AN OVERVIEW OF SIKA SOLUTIONS  
FOR BRIDGES, PAGE 24 – 47



We provide full range smart construction products and systems for many project types. You can access the SikaSmart online selection guide anytime and anywhere.



**Sika solutions for composite concrete bridges**

Concrete technology	Page 26
Concrete repair	Page 28
Structural strengthening	Page 30
Deck waterproofing	Page 32
Waterproofing	Page 34
Concrete protection	Page 36
Grouting and fixing	Page 38
Structural bonding	Page 42
Segmental bridge adhesive	Page 44

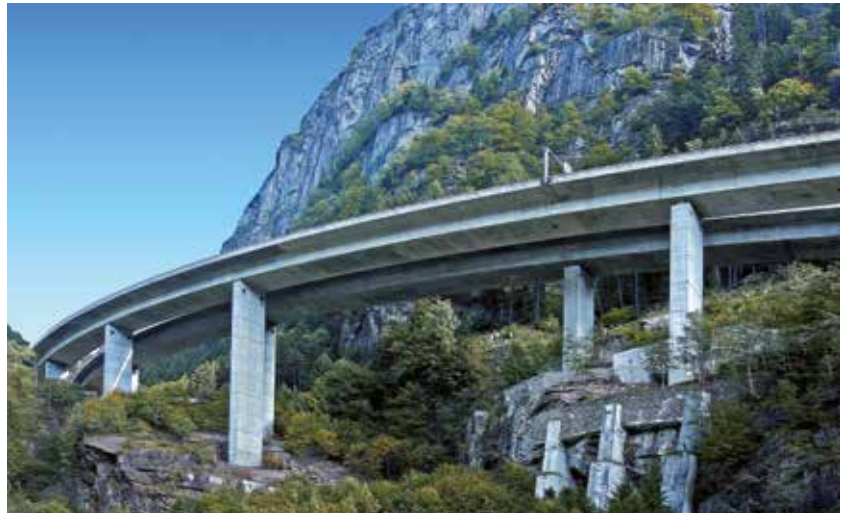

**Sika solutions for steel bridges**

Structural strengthening	Page 30
Deck waterproofing	Page 32
Grouting and fixing	Page 38
Steel protection	Page 40



**Sika solutions for wood and masonry bridges**

Masonry protection	Page 47
Structural strengthening	Page 47
Crack injection	Page 47



# CASE STUDIES

## COLORADO RIVER BRIDGE, HOOVER DAM BYPASS PROJECT, USA



### PROJECT DESCRIPTION

At nearly 700 meters long and 300 meters high above the river, the new composite bridge crosses the canyon south of the Hoover Dam. Bridge construction lasted from 2005 to 2010 and was completed on budget at US \$114 million.

### PROJECT REQUIREMENTS

For the cast-in-place reinforced concrete, a high performance concrete (HPC) mix design was specified (69 MPa – 10,000 psi). The precast concrete pier segments had to have an excellent visual finish and very high early strength up to 4,500 psi (30 MPa), within 12 – 16 hours, even during cold winter months. The segmental pier assembly and post-tensioning process was undertaken in a similar way to segmental bridge construction where a proven adhesive and lubricant were required.

### SIKA SOLUTION

All of the high performance concrete requirements set by the engineers were met using Sika® ViscoCrete® Technologies. Sika® Rapid Technology was used for accelerated hardening to achieve high early strength over 30 MPa within 16 hours where required. For the segmental adhesive, the engineers selected Sikadur®-31 SBA (Segmental Bridge Adhesive), as Sika is the global leader in this field and has previously completed numerous projects with Obayashi and others in China, Japan, the USA and worldwide.

## METRO DUBAI, UAE



### PROJECT DESCRIPTION

At over 70 kilometers in length, the Dubai Metro is the largest driverless, fully automated metro network in the world as of 2011. The first two lines have 58.7 kilometer-long elevated sections and 12.6 kilometer-long underground tunnel sections. The elevated sections were built using pre-stressed segmental bridge construction techniques, from huge precast concrete units about 10 meters wide by 4 meters long and weighing over 80 tons each. The 17,000 precast units used over 700,000 cubic meters of high performance concrete.

### PROJECT REQUIREMENTS

The large precast bridge units had uniform visual appearance demands, plus the concrete had to maintain a high slump over 150 millimeters with good consistency for more than an hour, followed by early strength development to facilitate rapid handling and erection. The ultimate compressive strength for the units was specified at 70 Mpa, which had to be reached with a low water to cement ratio (less than 0.29) to provide required long term durability.

### SIKA SOLUTION

All concrete mix designs for the project were achieved using Sikament® NN (Sikament® NNS in high summer temperatures over 35°C) and other compatible Sika admixture technologies, to meet or exceed all requirements on this prestigious project.

## REHABILITATION OF THE BAGO BRIDGE NEGROS OCCIDENTAL, PHILIPPINES



### PROJECT DESCRIPTION

Old Bago Bridge used to be a steel span structure, 200 meters long and 12 meters above the Bago River. The bridge was able to withstand threats of time and war until 1991, when typhoon Ruping hit Negros. The bridge was destroyed by floods induced by strong wind and rain. One of Bago City's iconic landmarks, the bridge acted as the primary access to the South Negros Island and needed to be rebuilt.

### PROJECT REQUIREMENTS

Since the bridge was reconstructed at 270 meters long, traffic loads have increased. This is related to the main crop in the island, sugar cane, which is quite heavy when transported by truck. As a result, the existing infrastructure strength became insufficient to handle current traffic conditions. The retrofitting method had to ensure minimal disturbance for public commuters, since no traffic detour was possible due to the distance of 17 kilometers to the nearest alternative route.

### SIKA SOLUTION

The Sika solution was based on the SikaWrap® and Sika® CarboDur® CF RP range, which provided a simple, efficient solution. The application of the products did not modify the existing traffic patterns, thereby avoiding interference with the daily activities of inhabitants of Negros Island.

## RENOVATION OF OLD LIBERTY BRIDGE ON THE DANUBE RIVER, BUDAPEST, HUNGARY



### PROJECT DESCRIPTION

On the 333 meter long bridge, tram rails run down the middle flanked by roadways and sidewalks. Per the historic 19th century design, it's a steel lattice-bridge. From 1998 to 2000 the visible steel structure had been fully maintained with a modern corrosion protection system. During the renovation between 2007 to 2009, some elements were changed or strengthened. According to the new plan, the deck and steel elements work as a composite structure. Thus, a new concrete bridge-deck was installed which would transmit stresses to the steel elements.

### PROJECT REQUIREMENTS

Due to the composite structure, the level of concrete deck shrinkage had to be kept low with a special concrete mix at a low cost. For this matter, the structural engineers and the ready-mix supplier wanted at least two different possible solutions.

### SIKA SOLUTION

The winning mix design which met all requirements included the following components: Sika® ViscoCrete®-1035 and Sika® Control-40.

For corrosion protection, the following were used: SikaCor Zinc R (zinc-rich primer), SikaCor EG 1 (epoxy MIO intermediate layer) and Sika Permacor 2330 (acrylic polyurethane topcoat).

# CASE STUDIES

## BRIDGE REHABILITATION LORCA, SPAIN



### PROJECT DESCRIPTION

Lorca, located in southwestern Spain, was a significant frontier town in the Middle Ages between Muslim and Christian territories. The town was severely damaged by an earthquake in 2011. The seismic movements exceeded the anticipated magnitudes of the existing national seismic code. Constructed in 1910, the bridge is considered as the second oldest reinforced concrete bridge in Spain and is thus part of the town's heritage.

### PROJECT REQUIREMENTS

Although the structure was showing signs of deterioration before the earthquake, the subsequent seismic accelerations caused significant damages in the form of cracks and breakage of the concrete members. This led local authorities to carry out a complete rehabilitation of the structure, including existing damage repair as well as structural retrofitting of the arches.

### SIKA SOLUTION

The structural rehabilitation included injection of cracks with Sikadur®-52, and structural repair and restoration done with the Sika MonoTop® mortar range. The main longitudinal arches were confined with SikaWrap®-230 C laminates, which drastically limits lateral expansion of the member under compressive forces and increases their load-carrying capacity. This solution allowed for more efficient control of the limited execution time. The new techniques will provide a longer lifespan for this centenary bridge.

## PENANG BRIDGE PENANG ISLAND, MALAYSIA



### PROJECT DESCRIPTION

The Second Penang Bridge in Malaysia is a dual carriageway toll bridge connecting Bandar Cassia on mainland Peninsular Malaysia with Batu Maung on Penang Island. It is the second bridge to link the island to the mainland after the first Penang Bridge. The total bridge length is 24 kilometers, with the section over water being 16.9 kilometers, making it the longest bridge in Southeast Asia.

### PROJECT REQUIREMENTS

Two major requirements for the bridge were to build it to last 120 years without major maintenance and to withstand earthquakes up to a 7.5 magnitude on the Richter scale.

### SIKA SOLUTION

To achieve a long lifespan, the concrete was designed with low chloride permeability and a thick cover. As an additional measure, deep penetrating hydrophobic impregnation Sika-gard®-705 L was used to protect 180,000 square meters of concrete surface area including the piers, pile caps and spun piles (exposed part during the low tide). Sika also supplied Antisol A curing compound, to improve concrete quality.

Installed with a high damping natural rubber (HDNR) bearing, an effective seismic isolation system enables the bridge to withstand a maximum 7.5 earthquake. The bridge is the longest bridge in the world to be installed with such a system. It is also the first in Malaysia to be installed with seismic expansion joints, which allow movements during an earthquake.



**WOODEN BRIDGE  
SINS, SWITZERLAND**



**PROJECT DESCRIPTION**

The famous wooden bridge over the Reuss River is over 200 years old and was built in 1807 with an original design capacity of 12 tons. Today, the bridge also serves as a back-up route for heavy vehicles, with required loading of 20 tons.

**PROJECT REQUIREMENTS**

The residents opposed an option to replace the historic bridge with a new structure, so refurbishment and strengthening to upgrade the whole structure was done in 1991.

The structural strengthening of this timber bridge was part of a long-term study and was one of the first Sika CarboDur® strengthening projects on wooden structures. The system solution was selected for its excellent mechanical properties and minimal visual impact, as retaining the visual appearance of the bridge was a key decision factor.

**SIKA SOLUTION**

To refurbish the bridge, the deck was removed and rebuilt. Sika CarboDur® CFRP plates were bonded to the bottom of the crossbeams to reduce deflection and were left exposed and uncoated to facilitate inspection and assessment. To date, the installation remains maintenance free.

**BELTON LANE BRIDGE  
GRANTHAM, UNITED KINGDOM**



**PROJECT DESCRIPTION**

Belton Lane Bridge crossing the Whitham River, had an old worn asphaltic concrete overlay with a traditional bituminous sheet waterproofing layer underneath. Over time, water ingress had started to attack the concrete structure below the waterproofing, resulting in a potential reduction in design life of the bridge.

**PROJECT REQUIREMENTS**

Lincolnshire County Council decided to take away the whole existing system including the bituminous sheet waterproofing, level out the slightly attacked concrete surface and install a new fast curing, crack bridging, spray applied waterproofing membrane & innovative tack-coat system, fully tested and certified according to BBA-HAPAS, and finished with a new asphaltic concrete overlay.

**SIKA SOLUTION**

Sika offered the already ETA 033 certified, fast curing, bridge deck waterproofing system consisting of Sika® Concrete Primer, Sikalastic®-841 ST spray applied membrane and a tack coat for the asphalt overlay consisting of Sika® Concrete Primer broadcast with our innovative Sikalastic®-827 HT hot melt pellets.

This system provides excellent tensile and shear strength properties with an increased bond to both the concrete substrate and the asphaltic concrete overlay, increasing driver safety & potentially reducing long term maintenance costs.

# BRIDGE DESIGN CONSIDERATIONS FOR COST EFFECTIVE, LONG LASTING AND SUSTAINABLE SOLUTIONS

## **DURABILITY**

Bridges are designed to maintain their service and function over long periods of time. During this service life, the concrete, steel and other materials are subjected to many aggressive influences, including variable loading and vibration, extreme weather conditions, the presence of chlorides in de-icing salts, freeze and thaw cycles and airborne chlorides in marine environments.

For new bridges, engineers need to produce materials that are able to achieve this long service life. All relevant Codes of Practice and Standards must be closely followed, such as adequate concrete cover over the steel reinforcement. Many ex-

isting bridges are not built according to such latest standards, which is one reason for early damage and deterioration.

To reduce maintenance costs, materials should only be applied that have proven durability, can increase the service life and reduce the frequency of such maintenance. Sika provides an extensive range of solutions for the repair, protection and strengthening of bridge structures, to ensure they can meet required durability standards.

## **SUSTAINABILITY**

In addition to durability, sustainability and environmental responsibility are important components of bridge structure



refurbishment and construction. The environmental impact of such public works is an increasingly important part of every project's pre-contract 'risk assessment' under the latest regulations.

The responsible use of our limited natural resources is essential for future generations. Therefore the whole bridge refurbishment and new construction process should be considered in relation to the selection of materials which are sustainable and ecologically harmless.

This includes the potential to minimize pollution-increasing traffic delays, decrease power consumption in material production, safe waste and packaging disposal and minimizing

use of scarce resources. Sika strives for a more sustainable environment by optimizing our logistics, reducing energy consumption, reducing natural resources in our production processes and by developing innovative, solvent-free solutions to limit the release of VOC's (volatile organic compounds). Sika actively supports numerous green projects on a global, regional and local basis, working together to create a more sustainable future worldwide.

#### **LIFE CYCLE MANAGEMENT**

Appropriate life cycle costing and management in all areas of bridge design, construction and management, including the correct maintenance, not only safeguards the owner's investment, but also ensures the safety of the bridge users and maintains its capabilities and functions. Frequently these landmark structures are an important feature of a city, region or even a national heritage.

Life cycle costing and management provides bridge owners with the best approach to minimize closure times and increase periods required between scheduled maintenance works, thereby achieving the lowest total cost over the full service life of the structure.

Sika provides bridge owners and their maintenance managers the right design and planning tools, followed by thoroughly designed and proven, complete solutions and systems, to greatly increase the time between the necessary maintenance or repair cycles. This accounts for considerable savings in the overall defined life cycle costs, the bridge owner's and users' time, and delay and closure costs. Plus, it decreases the environmental impact of the bridge.

## **SIKA – 100 YEARS OF EXPERIENCE**

Sika has experience in the construction and refurbishment of all types of bridge structures. With renowned, thoroughly proven and innovative systems in a complete product range, Sika can provide bridge maintenance contractors and their customers with the appropriate solution for all types of projects. These include: concrete repair and protection, concrete technology, deck waterproofing, structural strengthening, steel corrosion protection, watertight joint sealing, segmental bridge adhesive, high performance grouting and structural bonding solutions (rigid and elastic).

Sika's depth of expertise comes from global experience, gained over 100 years in the complex business of construction chemicals. Sika produces consistent quality-controlled products and systems, all supplied to the site through efficient logistics. Overall it is our well trained Sika specialists who are key to our success in providing durable, cost efficient and effective bridge solutions.



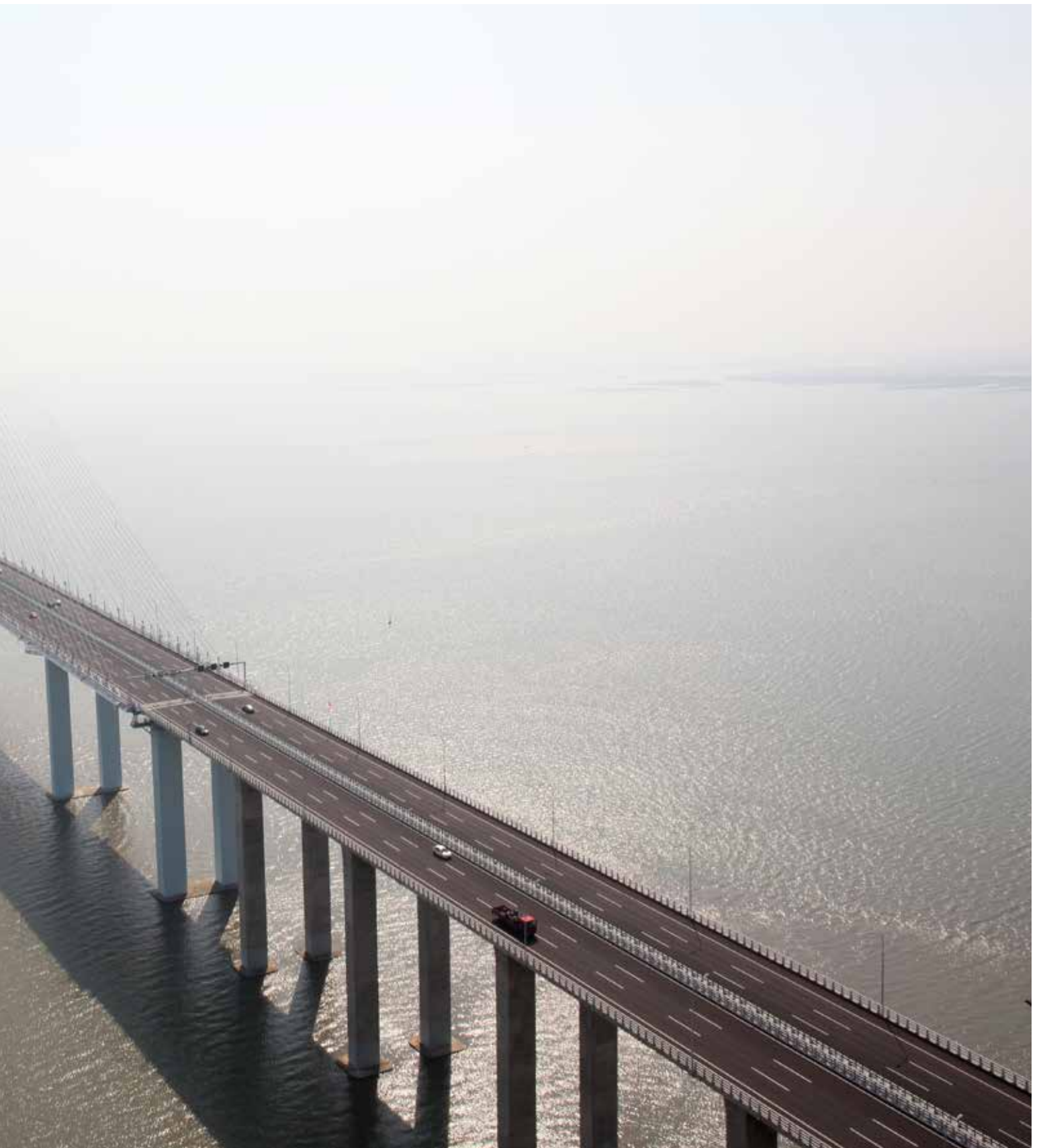

# AN OVERVIEW OF DAMAGE AND DETERIORATION – THE ROOT CAUSES

1



## Steel Reinforcement Corrosion

Root Cause: (Examples)

- Chloride ingress
- Carbonated concrete
- Stray electrical current

2



## Non-Structural Cracks

Root Cause: (Examples)

- Shrinkage
- Thermal movement
- Alkali Aggregate Reaction

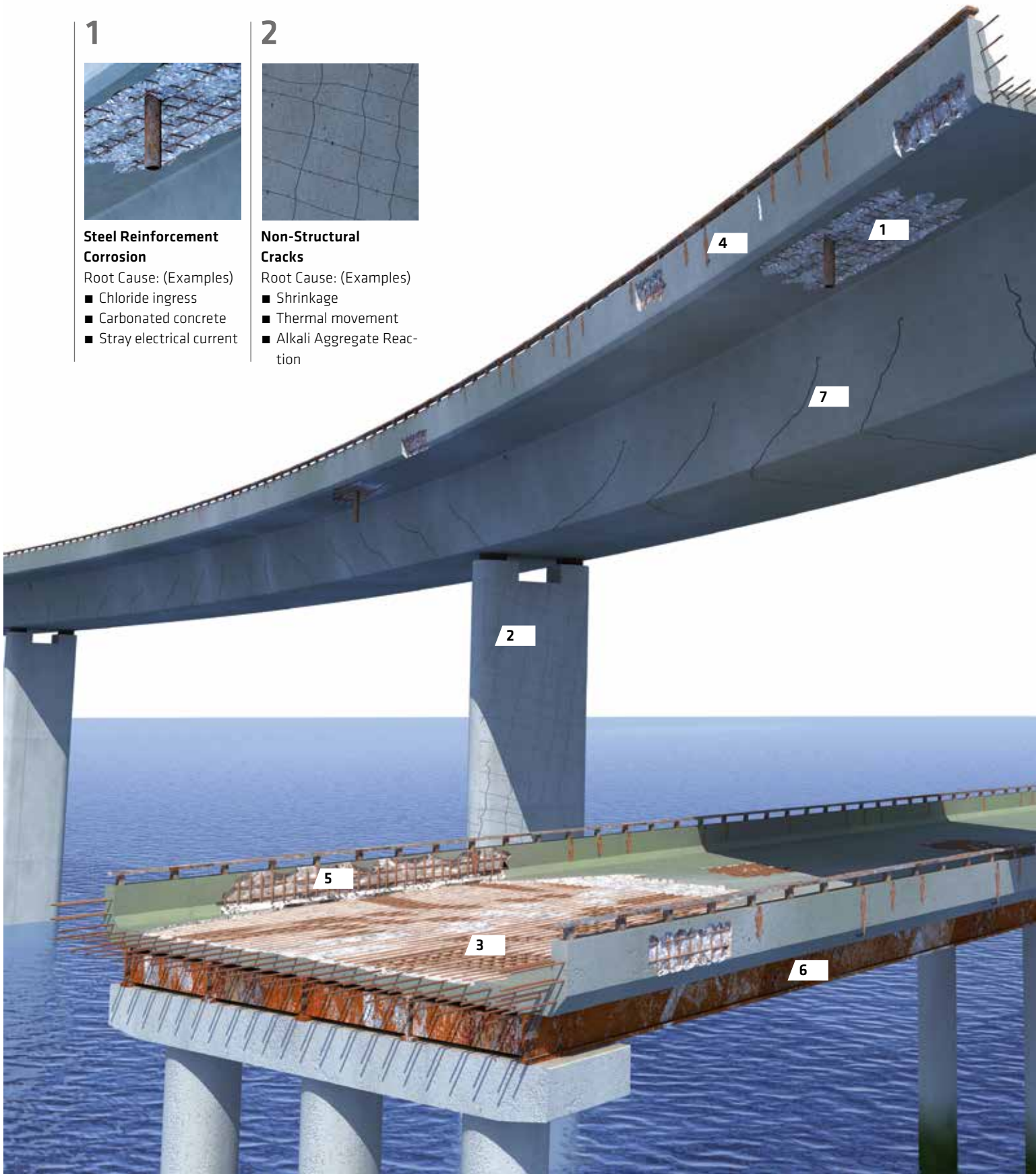

# BRIDGE EXPOSURES



## Water Ingress

Water can penetrate naturally through the capillary pore structures of reinforced concrete. In areas of carbonated concrete, or where there is a high chloride content on the surface of the steel reinforcing bars, reinforcement corrosion, cracks or spalling can occur on the surface.

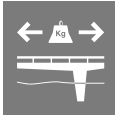

## Dynamic and Static Load

Overloading due to increasing traffic loads, inadequate design, damage to the structure, stress/fatigue failure, earthquake effects, or any other mechanical impact such as vehicle impact, can all exceed or reduce the load capacity of the structure.



## Wide Temperature Variation

By their nature and locations, bridges are subjected to a wide variation of temperatures between day and night/winter and summer conditions, or between different sides or surfaces of the structure. These frequent cycles result in thermal stresses and movement in the concrete structure that can also result in cracks.

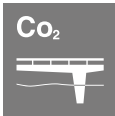

## Carbon Dioxide

Carbon Dioxide ( $\text{CO}_2$ ) reacts with the Calcium Hydroxide ( $\text{Ca}(\text{OH})_2$ ) in the pore liquid of the cement matrix of concrete structures and deposits as calcium carbonate ( $\text{CaCO}_3$ ). This process known as carbonation reduces the protection of embedded steel reinforcement, when the process reaches the reinforcement bars.



## Chlorides Ingress

Chlorides come from de-icing salts used in winter, or from salt water in marine environments. They can penetrate the concrete structure and once they reach the reinforcement bars, they can locally destroy the passivation film causing fast pitting corrosion.



## Freeze / Thaw Action

The freeze thaw process creates stresses in the concrete matrix due to the expansion of free water in the capillary pores during freezing conditions; this can result in scaling of the surface of poor quality concrete. This action is also greatly accelerated by the presence of chlorides in the water.



## Surface Erosion / Abrasion

Concrete elements submerged in water such as the bridge piers or columns, are continuously exposed to erosion and abrasion of their surfaces. Damage occurs from the action of fast flowing water, and the particles of sand or other solid materials in the water.



## Fire Damage

Fire due to traffic accidents, for example, can result in a reduction of the structural integrity of any of the concrete elements including the columns, decks or precast segments etc.



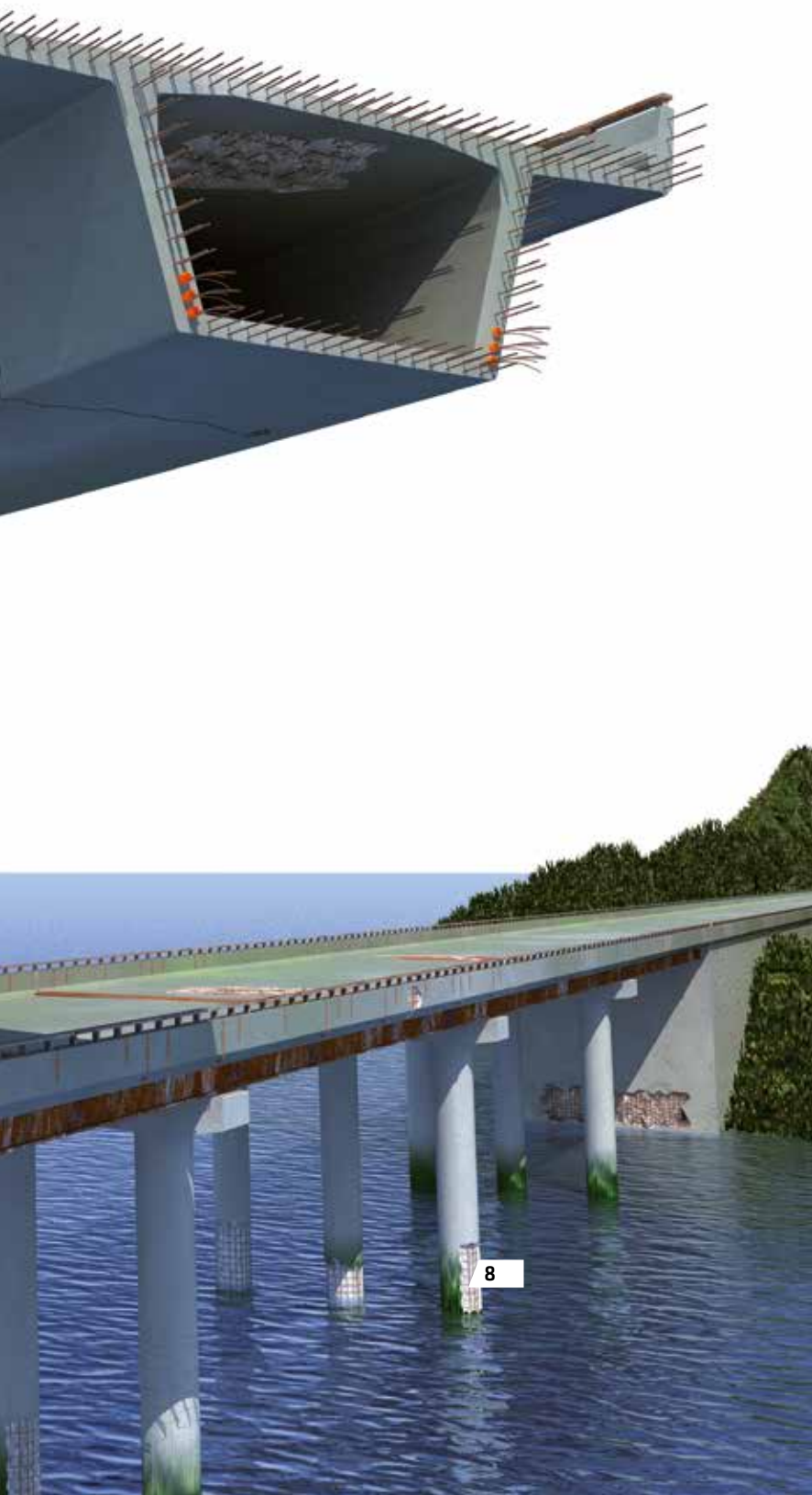

3

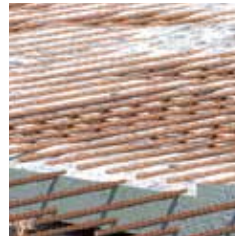

**Deck Corrosion  
Reinforced concrete or  
steel deck)**

Root Cause: (Examples)

- Failing or inadequate waterproofing
- Chloride ingress
- Water ingress

4



**Leaching / Efflorescence**

Root Cause: (Examples)

- Water ingress

5



**Concrete Spalling**

Root Cause: (Examples)

- Steel reinforcement corrosion
- Freeze/Thaw action
- Impact

6

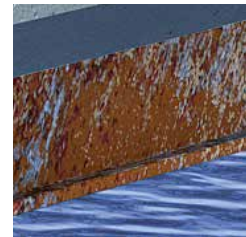

**Structural Steel Corrosion**

Root Cause: (Examples)

- Inadequate steel coatings
- Chloride ingress
- Water ingress

7



**Structural Cracks**

Root Cause: (Examples)

- Overloading
- Structural movement/  
Vibration
- Earthquake impact

8

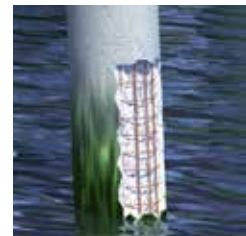

**Scaling of Concrete  
Surface**

Root Cause: (Examples)

- Erosion
- Abrasion
- Salt expansion
- Freeze/Thaw action

8

# GENERAL BRIDGE CONSIDERATIONS

Before defining the construction repair and protection strategy including detailed procedures, the specific bridge project requirements must be considered. These requirements can have an important influence in determining the correct design,

planning and construction procedures, together with the future maintenance works necessary for the bridge. Examples of these project related requirements are outlined below.

## Durability

Remedial works on a bridge structure can have a significant cost; hence the frequency of these works should be as far apart as possible. Therefore the products used in bridge works must provide adequate durability to extend the frequency to the defined service life.



## Total Life Cycle Costing

The total costs must take into account the actual costs of the re-medial works plus the maintenance costs of the defined service life.

This significantly influences the selection of the appropriate refurbishment or construction concept and the specific materials to be used.



## Duration of Closure

The time for the bridge lane or road closure has a direct influence on the cost of construction works. The choice for the selection of systems must allow a fast return to service and therefore reduce the disruption of traffic to a minimum.



## Exposures /Site Conditions

The specific site exposure and environmental conditions, such as the climate, access and space for materials application, also significantly influences the concept selection and/or the appropriate materials and application techniques.



## Aesthetic Issues

Bridges are often built with innovative designs and can become well known landmarks in a region. Therefore the aesthetic considerations can often also play an important role in the design and execution of bridge works.



## Traffic Flow

Minimize traffic disruption long periods of construction works have to be prevented. Repairs also have to be done under live traffic loading. This requires special materials and only systems which are specifically tested to be suitable for application under dynamic load will achieve the required quality and durability.



## System Compatibility

Remedial work on complex bridge structures often demands a complete and integrated system buildup.

It is very important that all of the products used are compatible. The use of one full range system supplier with proven compatible products and systems ensures that this is achieved.



## Ecology

Environmentally friendly and sustainable materials such as solvent-free products help to safeguard the environment. These are an increasingly important requirement and in some countries, additional taxes now have to be paid for products that release Volatile Organic Compounds (VOC's).











# GENERAL BRIDGE REFURBISHMENT PROCEDURES

The construction, repair and protection of bridges must always be executed according to all relevant local Standards and Regulations. After a detailed condition survey and root cause analysis, the right procedures for successful construction of refurbishment can be defined. Standards (such as European

Standard EN 1504-9) define principles and methods to refurbish damaged concrete and components. Please refer to our brochure 'The Repair and Protection of Reinforced Concrete with Sika' for more information relating to repair and protection according to EN 1504-9.

Types of Damage / Defects (Examples)		Possible Principles/Methods	
		For the Repair	For the Protection
Concrete Spalling / Scaling of Concrete Surface		<ul style="list-style-type: none"> <li>Concrete Restoration (Method 3.1 / 3.3)</li> </ul>	<ul style="list-style-type: none"> <li>Protection against Ingress (Methods 1.1 / 1.2 / 1.3)</li> <li>Physical Resistance (Method 5.1 / 5.2 / 5.3)</li> </ul>
Steel Reinforcement Corrosion		<ul style="list-style-type: none"> <li>Restoring passivity (Method 7.2)</li> </ul>	<ul style="list-style-type: none"> <li>Increasing resistivity (Method 8.1 / 8.2 / 8.3)</li> <li>Cathodic Control (Method 9.1)</li> <li>Cathodic Protection (Method 10.1)</li> <li>Control of anodic areas (Methods 11.1 / 11.2 / 11.3)</li> </ul>
Structural Cracks		<ul style="list-style-type: none"> <li>Concrete Restoration (Methods 3.1 / 3.3)</li> <li>Crack Injection (Methods 4.5 / 4.6)</li> <li>Structural strengthening (Methods 4.1 / 4.3 / 4.4 / 4.7)</li> </ul>	<ul style="list-style-type: none"> <li>Not applicable</li> </ul>
Non-Structural Cracks		<ul style="list-style-type: none"> <li>Filling of cracks (Method 1.5)</li> </ul>	<ul style="list-style-type: none"> <li>Protection against Ingress (Method 1.1 / 1.2 / 1.3)</li> <li>Moisture Control (Method 2.1 / 2.2 / 2.3)</li> <li>Physical Resistance (Methods 5.1 / 5.2 / 5.3)</li> </ul>
Leaching / Efflorescence		<ul style="list-style-type: none"> <li>Filling of cracks (Method 1.5)</li> </ul>	<ul style="list-style-type: none"> <li>Protection against Ingress (Method 1.1 - 1.8)</li> <li>Moisture Control (Methods 2.1 / 2.2 / 2.3)</li> </ul>
Structural Steel Corrosion		<ul style="list-style-type: none"> <li>(None)</li> </ul>	<ul style="list-style-type: none"> <li>ISO 12944 Refers to the Corrosion Protection of Steel Structures</li> </ul>

# SIKA'S LIFE CYCLE ASSESSMENT APPROACH

**Life Cycle Assessment (LCA)** is a standardized method to assess and compare the inputs, outputs and potential environmental impacts of products and services over their life cycle. LCA's are increasingly recognised as the tool to evaluate the sustainability of products and systems.

Sika carries out LCA's according to the ISO 14040 series and the standard EN 15804. The impact assessment methodology used is CML 2001. The data for the Sika LCA is based on public databases, such as those from ecoinvent, the European Reference Life Cycle Database (ELCD) and PE-GaBi, plus the specific data from Sika production plants and products.

Sika evaluates all impact categories and resource indicators deemed as important according to the relevant standards.

Cumulative Energy Demand (CED), Global Warming Potential (GWP) and Photochemical Ozone Creation Potential (POCP) are considered to be most relevant for concrete construction, repair and protection:

- Cumulative Energy Demand (CED) is the total amount of primary energy from renewable and non-renewable resources.

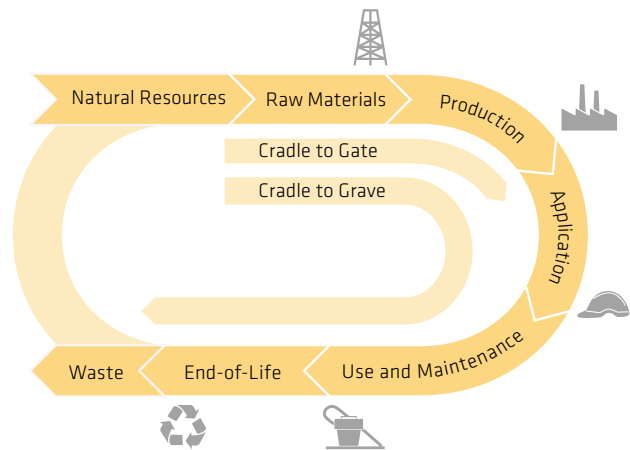

- Global Warming Potential (GWP) is the potential contribution to climate change due to greenhouse gas emissions.
- Photochemical Ozone Creation Potential (POCP) is the potential contribution to summer smog, related to ozone induced by sunlight on volatile organic compounds (VOC) and nitrous oxides (NO<sub>x</sub>).



# SUSTAINABLE CONCRETE PROTECTION

Sika LCA on concrete strategies for reinforced concrete bridges are based on a Cradle to Grave approach. Potential environmental impact of products for concrete protection are investigated from raw material extraction, production, application and use to final disposal at the end of life stage. Construction and end-of-life scenario of the reinforced concrete bridge itself are excluded.

For this study, we compare traditional systems (scenario 1) comprising resurfacing mortar and protective coating with scenario 2 (known as SO<sub>2</sub> system) which combines hydrophobic impregnation and protective coating.

As both products studied in the LCA have similar expected life spans, the study is based on the protection of one square meter of concrete.

Scenario	Building phase	Refurbishment step	Action	Processes/Products	Product quantities	Surface area considered
Scenario 1 (Traditional system)	New construction	Resurfacing	SPT*	HWP treatment	-	1 m <sup>2</sup>
			PA**	Resurfacing mortar (WS)	4 kg	
		Protective coat	PA**	Solvent based acrylic coating (ALS)	0.4 kg	
Scenario 2 (SO <sub>2</sub> system)	New construction	Hydrophobic impregnation	SPT	LWP treatment	-	1 m <sup>2</sup>
			PA**	Water based silane emulsion (ALS)	0.15 kg	
		Protective coat	PA**	Water based protective coating (ALS)	0.45 kg	

\*SPT = Surface pre-treatment (HWP = high water pressure, LWP = low water pressure)

\*\*PA: Product application (WS = wet spray, ALS = airless spray)

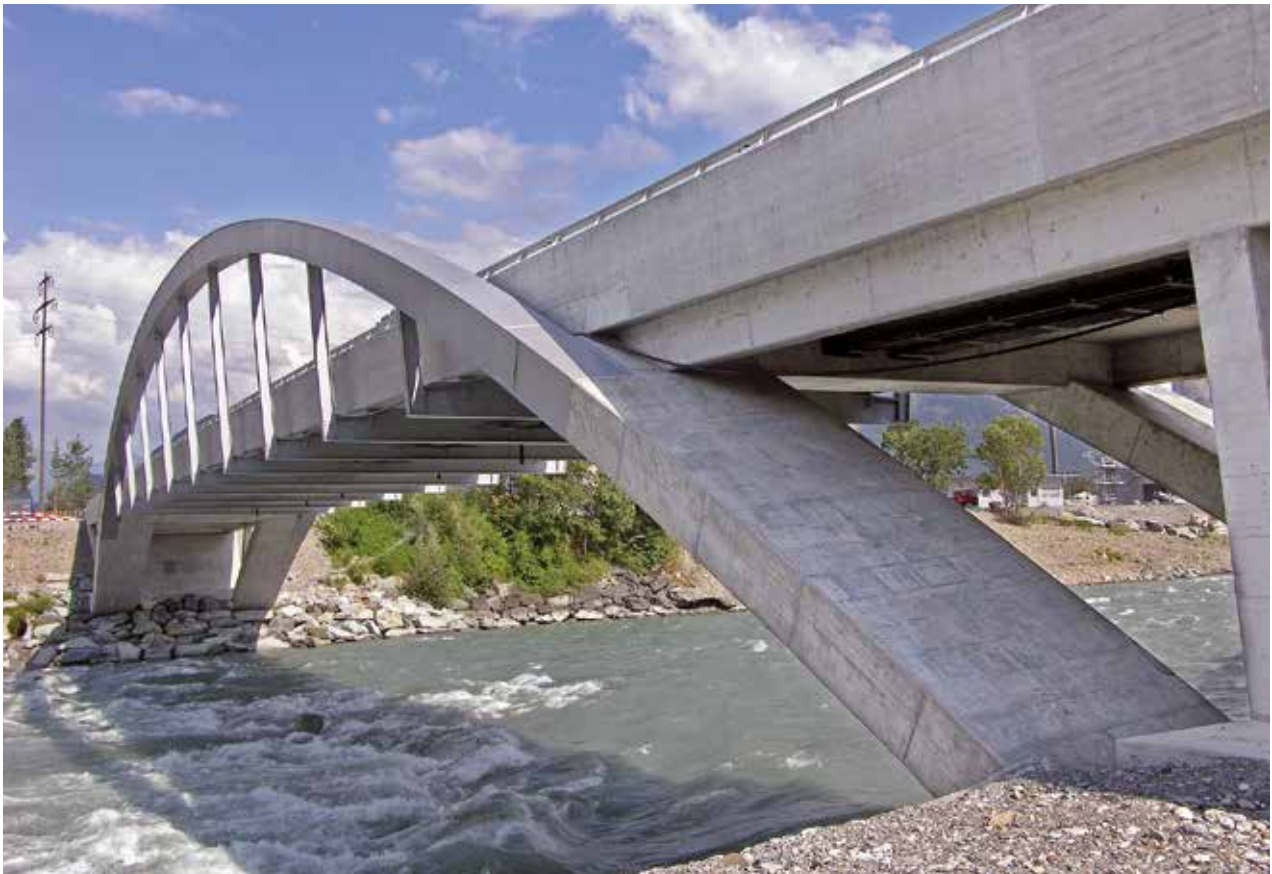

# SUSTAINABLE CONCRETE PROTECTION

The concrete protection Sika System SO<sub>2</sub> (scenario 2) not only has a significantly lower environmental impact compared to a well-established and well-proven system but also promotes significant time savings for the applicator throughout execution of the concrete protection works. This allows for such benefits as a faster re-opening of the bridge to traffic.

## Time frame (e.g. for a surface of 1000 m<sup>2</sup>)

### Scenario 1

Traditional system



Total application time: **11 days**

- 2 days** Surface preparation
- 2 days** Resurfacing mortar application
- 5 days** Curing
- 2 days** Protective coating application

### Scenario 2

SO<sub>2</sub> system



Total application time: **4 days**

- 1 day** Surface preparation
- 1 day** Drying
- 1 day** Hydrophobic impregnation
- 1 day** Coating application

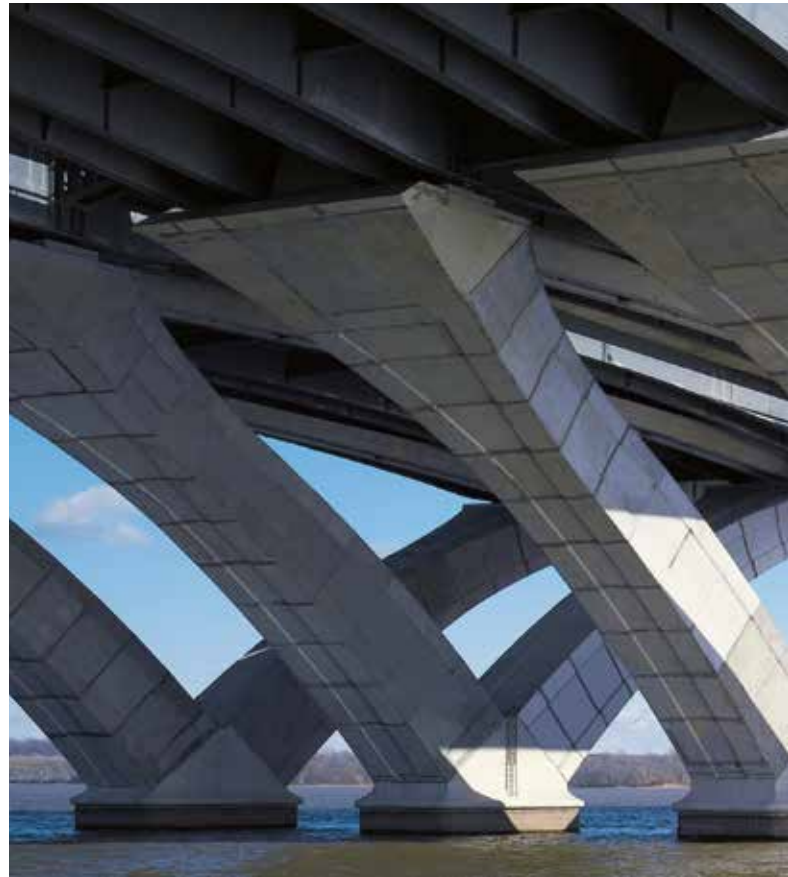

CML2001, POCP [kg Ethene-eq./m<sup>2</sup>]

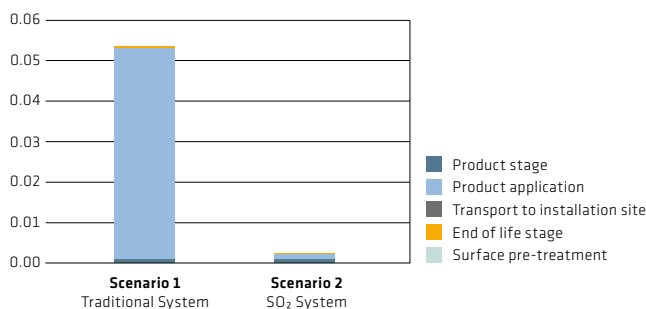

In the case of chemical smog (POCP), the SO<sub>2</sub> system has a significantly lower impact than the traditional system due to the use of solvent-based coatings, enabling greater resource efficiency (lower material consumption over the whole life cycle). For example, if system SO<sub>2</sub> (scenario 2) is implemented over 1,000 square meters, it would save about 500 kilograms of solvent-based coating when compared to the traditional system (scenario 1).

## Global Warming Potential (GWP)

CML2001, GWP [kg CO<sub>2</sub>-eq./m<sup>2</sup>]

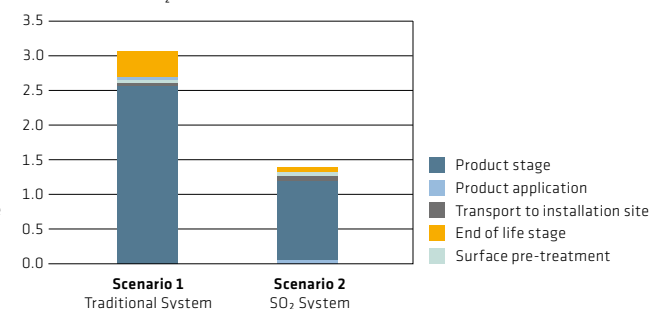

In the case of Global Warming Potential (GWP), the SO<sub>2</sub> system has a significantly lower impact than the traditional system due to the use of solvent-based coatings. For example, if system SO<sub>2</sub> (scenario 2) is implemented over 1,000 square meters, it saves about 1.7 tons of CO<sub>2</sub> (equivalent to the transport of 15 tons by a truck over about 4,000 km).



### Cumulative Energy Demand (CED)

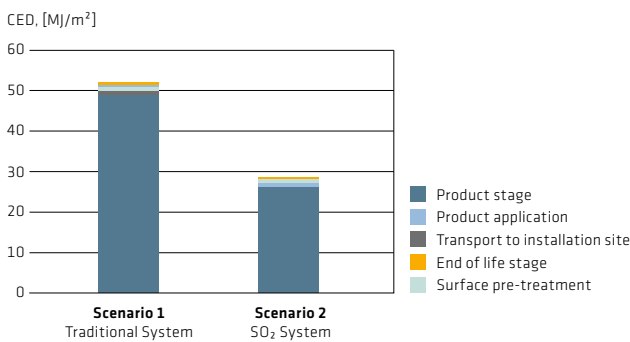

In the case of Cumulative Energy Demand (CED), the SO<sub>2</sub> system has a significantly lower impact than the traditional system due to the use of solvent-based coatings. For example, if system SO<sub>2</sub> (scenario 2) is implemented over 1,000 square meters, it saves the use of about 2.5 drums of oil when compared to the traditional system (scenario 1).

### CONCLUSION

The LCA has clearly demonstrated that although it does not have a negative influence on durability, the CO<sub>2</sub> System is an efficient way to protect concrete structures with regards to time management, cost aspects and environmental impact. The main advantage of the CO<sub>2</sub> system is that it eliminates the need for intensive surface preparation required to apply a resurfacing mortar. Total quantity of material used on the job site is therefore reduced. Work is carried out faster with a lower impact on the environment while the durability objective is still maintained.

# SIKA – YOUR COMPLETE SYSTEM SUPPLIER

Sika is a global market and technology leader in specialist construction chemicals that can be used for new bridge construction and maintenance. We have manufacturing facilities worldwide and regional subsidiaries in over 70 countries. Our extensive experience and expertise have been gained over the past 100 years of working on building and refurbishment of

reinforced concrete bridges, steel bridges and other civil engineering structures.

Sika today provides a complete range of innovative products and systems especially designed to solve all challenging requirements in differing bridge projects anywhere in the world.

## EXAMPLES OF SIKA'S LEADING INNOVATIONS FOR BRIDGE PROJECTS

### CONCRETE ADMIXTURES



For durable concrete mix design and placing.

### WATERTIGHT JOINT SYSTEMS



For watertight sealing of all types of movement and construction joints.

### LIQUID APPLIED WATERPROOFING MEMBRANES



For durable crack-bridging protection of bridge decks.

### CONCRETE REPAIR SYSTEMS



For secure concrete repair works even under dynamic loading.

### CORROSION INHIBITORS



Protecting embedded steel reinforcement without changing the concrete appearance.

### POST-TENSIONING SYSTEMS



For highly efficient structural strengthening of reinforced concrete bridges.

Sika provides full support to bridge owners, architects, engineers and contractors with necessary technical advice and assistance to ensure a successful project. In particular for refurbishment projects, this includes assistance throughout the process, from the initial survey and assessment, root cause diagnosis, specification writing, detailing, method statements, on-site quality control and practical application assistance.

For new construction, Sika can offer support to design structures for a long service life. Sika's expertise can make a significant contribution in minimizing the total project cost over the full defined service life-cycle. Additionally, this expertise and our local presence globally, means that our clients and their customers have technical support to solve their specific problems, whether in the design office or on site.

### ADDITIONAL ARGUMENTS FOR SIKA ARE:



Sika's experience – continually developed since 1910.



Sika's expertise and competence – all over the world.



Sika's complete system compatibility – reliably proven and tested.



Sika guarantees – for a reliable partnership.



Sika's innovative solutions and systems – for durable bridge structures.



Sika's full project support – from design to completion, through all project phases.



Sika's complete product range – all solutions from one single-source supplier.



Sika's application engineering – for the most efficient and cost effective application.



Sika's additional testing developments – for totally reliable products and systems.

# AN OVERVIEW OF SIKA SOLUTIONS FOR BRIDGES

1

## CONCRETE TECHNOLOGY

see page 26 / 27

- High early strength concrete
- Watertight concrete
- Rapid hardening concrete
- High durability concrete
- Ultra high strength concrete

2

## CONCRETE REPAIRS

see page 28 / 29

- Bonding bridge primers
- Reinforcement corrosion protection
- Hand applied concrete repairs
- Machine applied repairs
- Levelling and fairing mortars





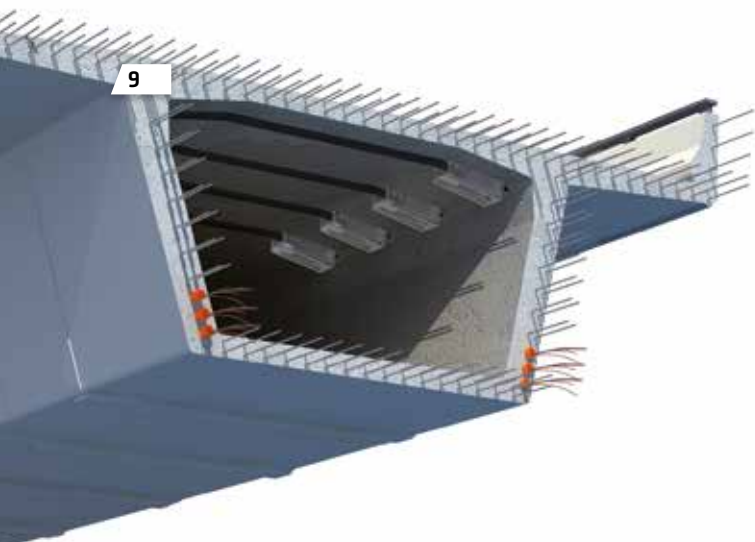

9

3

### STRUCTURAL STRENGTHENING

see page 30 /31

- Flexural strengthening systems
- Shear strengthening systems
- Axial strengthening systems
- Impact strengthening systems
- Earthquake strengthening solutions

4

### WATERPROOFING

see page 32 - 35

- Bridge deck protection
- Joint sealing solutions
- Watertight structural injection
- Waterproof epoxy overlays
- Liquid applied waterproofing membranes
- Bonding primers for asphalt



6

5

### CONCRETE PROTECTION

see page 36 /37

- Hydrophobic Impregnations
- Impregnations
- Rigid and flexible coatings
- Corrosion inhibitors
- Galvanic and cathodic protection systems

6

### GROUTING AND FIXING

see page 38 /39

- Structural grouting systems
- Embedding and fixing mortars
- Elastic rail fixing grouts

7

### STEEL CORROSION PROTECTION

see page 40 /41

- Steel corrosion protection systems
- Steel maintenance systems
- Steel cable protection systems

8

### STRUCTURAL BONDING

see page 42 /43

- Structural epoxy adhesives
- Structural resin anchoring
- Structural resin injection

9

### SEGMENTAL BRIDGE

see page 44 /45

- Segmental bridge adhesive

# SIKA SOLUTIONS FOR CONCRETE TECHNOLOGY

## Overview

Concrete structures such as bridges can be exposed to a broad range of forces and strains, starting internally with mechanical stresses resulting from the construction type and extending to various external attacks. Enormous stressors on the concrete include such factors as extreme hot or cold temperature conditions and fluctuations, aggressive water or chemicals, continually rolling, abrading or pulsating strains on surfaces, or even in extreme cases the impact of fire. Therefore, a highly durable concrete is necessary for the construction or refurbishment of a bridge.

## Requirements

- Highly durable concrete with reduced permeability and excellent resistance to the anticipated future exposure
- High early strength development to reduce closure time
- Extended workability and excellent flowability to allow fast, easy and secure concrete placing with assured concrete performance
- Optimized utilization of the available raw materials (including recycled aggregates)

## Sika in Concrete Production

The development and production of innovative concrete mix designs using special admixtures has been a core Sika business since 1910. Our technology and high quality products have been continuously developed during this century of experience. Sika provides the most complete range of admixture technologies and products for the efficient replacement of highly durable concrete.

## Added Value from Sika in Concrete Technology

### Secure connection and bond of 'new' to 'existing' concrete

With SikaTop® Armatec®-110 EpoCem® anti-corrosive bonding primer, durable and high strength adhesion of new concrete to the existing bridge decks is achieved with the correct transmission of structural shear loads.

### Advantages:

- High strength bonding of new to existing concrete
- Structural shear load transmission
- Extended open times during concreting operations
- Fast and easy application by spray



### Sika Solutions for Highly Durable Concrete

Increasing the durability of concrete by using:

- SikaControl®-40 to minimize shrinkage of concrete
- SikaAer® to increase the frost and freeze/thaw resistance
- SikaFume® silica fume to increase the density of the matrix
- Sika® FerroGard® corrosion inhibitor to prevent the corrosion of steel reinforcement
- Sika® Antisol® for controlled curing of the concrete for significantly enhanced durability
- SikaFiber® for even distribution of cracks and increased mechanical properties like impact resistance, flexural strength or fire resistance



### Sika Solutions for High Early Strength Concrete

High early strength concrete for reduced closure times is achieved by:

- High range water reduction and plasticizing with Sika® ViscoCrete® and SikaPlast® technology, to provide enhanced strength development and precisely controlled concrete workability
- Hardening or set acceleration to speed up the hydration process using SikaRapid® technology



### Sika Solutions for Self Compacting Concrete

Casting concrete with maximum flowability for specific periods of time without the need for vibration by the addition of:

- Sika® ViscoCrete® and Sika ViscoFlow® technology for highly flowable and workable concrete with optimized raw material usage, based on powerful water reduction with extended workability time
- Sika® Stabilizer® for improved stability of the Self Compacting Concrete even with inferior quality aggregates
- SikaFume® silica fume to provide increased density and durability of the matrix, with enhanced fresh concrete stability



# SIKA SOLUTIONS FOR CONCRETE REPAIRS

## Overview

Repairing damaged concrete is one of the primary requirements in the maintenance of concrete bridges. Localized spalling or full surface scaling of concrete surfaces has to be repaired with durable concrete repair materials. A sound and correctly repaired concrete substrate is also the basic requirement for any additional waterproofing, protection or strengthening systems to be applied.

## Requirements

- Full system compatibility (galvanic anodes, bonding bridge, repair mortar, levelling mortar) hydrophobic impregnation and concrete protection
- Approved for structural repairs where required (e.g. class R3 or R4 according EN 1504-3)
- Low crack sensitivity
- Fast and easy application
- Innovation systems reducing working steps

## Sika Concrete Repair Expertise

Sika provides an extensive range of thoroughly tested and proven repair materials and systems based on different technologies for each specific requirement and situation. These include bonding and corrosion protection primers, hand and machine applied repair mortars, suitable for vertical and overhead application, semi-fluid mortars for efficient bridge deck repairs, plus combined surface levelling and protection mortars, not requiring additional protective treatments (EpoCem®-technology).



## Added Value from Sika in Concrete Repair

### Testing Product Application under Dynamic Load

With the application for installation and performance testing of repair mortars under live dynamic loading, SikaTop® Armatec®-110 EpoCem® and Sika MonoTop®-412 N fulfill the requirements of German Standard ZTV-SIB, TL BE-PCC, 1999.

### Advantages:

- Maintain bond strength
- Maintain mortar cohesion
- No strength reduction

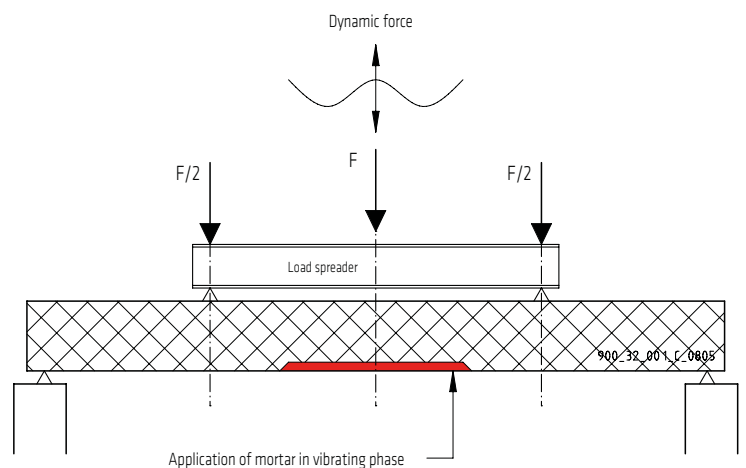

### Sika Solutions for Horizontal Repair Works

Thin-layer repair system for bridge decks:

- Bonding bridge primer for large area repairs (where relevant):  
SikaTop® Armatec®-110 EpoCem®
- Semi-fluid repair mortars for large area repairs:  
Sika MonoTop®-432 N
- Thixotropic repair mortars for local patch repairs:  
Sika MonoTop®-412 series
- Self-levelling, epoxy modified, cement based levelling mortars:  
Sikafloor®-81/-82 EpoCem®



### Sika Solutions for Vertical Repair Works

Structural concrete repair system for columns and beams:

- Bonding primer (where relevant):  
Sika MonoTop®-910 N or SikaTop® Armatec®-110 EpoCem®
- Hand or wet spray machine applied repair mortars:  
Sika MonoTop®-412 / -352 series
- Surface levelling and fairing mortars:  
Sika MonoTop®-723 N or Sikagard®-720 EpoCem®



### Sika Solutions for Overhead Repair Works

Structural concrete repair systems for soffits and other surfaces under live dynamic loading:

- Bonding bridge primer:  
SikaTop® Armatec®-110 EpoCem®
- Hand or machine applied repair mortar:  
Sika MonoTop®-412 series
- Surface levelling mortar:  
Sika MonoTop®-723 N



# SIKA SOLUTIONS FOR STRUCTURAL STRENGTHENING

## Overview

If the existing steel reinforcement is reduced in capacity due to corrosion, if the traffic loads are increased (i.e. permissible axle weights), or if the structural design or seismic resistance needs improvement, then reinforced concrete bridges have to be strengthened.

## Requirements

- High tensile resistance or high modulus of elasticity to reinforce and upgrade the structurally deficient beams, slabs, columns, etc.
- Easy to install and corrosion resistant materials for exposed environments.
- Fast application to reduce traffic closure times
- Durable, low maintenance solutions

## Sika in Structural Strengthening

Sika has been involved in structural strengthening since the development of the technology in the 1960's using bonded steel plates. Since 1991 Sika has also been a pioneer with the development of carbon fibre reinforced polymers based structural strengthening systems. As a leader in the structural strengthening of all types of reinforced concrete structures, Sika provides a full range of fully tested and approved strengthening systems.



## Sika Solutions for Shear Strengthening

Strengthening systems for shear strengthening of beams and columns, consisting of Sikadur® structural epoxy adhesives and:

- Prefabricated L-shaped plates – Sika CarboShear L for application on rectangular T-Beams
- SikaWrap® fabric strengthening system based on unidirectional carbon and glass fibers, for application on beams and beam-column-joints



### Sika Solutions for Flexural Strengthening

Structural strengthening systems for the flexural strengthening of bridge decks, beams and girders, consisting of Sikadur® structural epoxy adhesives and:

- The carbon fiber reinforced polymer based, pultruded plate system Sika CarboDur®, available with different E-Moduli and in various dimensions, for external application
- The carbon fiber reinforced polymer based Sika CarboDur® NSM system for application in near-surface slits



### Sika Solutions for Post-tensioned Strengthening

Structural strengthening system for post-tensioned strengthening of bridge decks and beams, consisting of:

- Tendon based on CarboDur® plates and special CarboStress® anchorage heads
- End-anchorage solutions based on project needs



### Sika Solutions for Axial Strengthening

Strengthening system for axial strengthening of columns (column confinement), consisting of Sikadur® epoxy adhesives and:

- Unidirectional SikaWrap® fabrics, based on carbon and glass fibers, available in a range of area weights



# SIKA SOLUTIONS FOR BRIDGE DECK PROTECTION



## PROTECTION OVERVIEW

Bridges are an essential part of modern infrastructure and are often subject to the harshest weather that climates have to offer. In order to maintain the durability over its design life, special attention should be given to the protection of exposed elements and critical areas such as the bridge deck itself, to prevent serious damage to the concrete and structural reinforcement. Due to constant movement, the deck waterproofing system must be able to accommodate dynamic traffic loads and bridge cracks whilst still maintaining a strong bond with both the substrate and asphalt road surface. Bonding failure can lead to loose or rucked road surfaces allowing water, chlorides and chemicals to attack the structure, reducing the design life.

## REQUIREMENTS

- Elastic crack-bridging properties under a wide range of temperatures.
- Resistance to chlorides and aggressive chemicals such as fuel, oils and hydraulic fluids.
- Easy and safe to install under different weather conditions and suitable for different substrate conditions.
- Fast application to reduce down time.
- Maintaining strong bond when vehicles break hard

## SIKA PROTECTION SOLUTIONS FOR CONCRETE BRIDGE DECKS



### Sikalastic®-841 ST / 851 WITH Sikalastic®-827 / HT

1. **Wearing course:** hot mixed asphalt / asphalt concrete (+140-180°C)
2. **Base course:** mastic asphalt (+240°C), or hot mixed asphalt / asphalt concrete (+140-180°C)
3. **Tack-coat:** Epoxy-/PU-based + Sikalastic®-827 LT/HT
4. **Waterproofing layer:** Sikalastic®-841 ST / 821 LV
5. **Primer:** Epoxy-based + broadcasted (QS 0.4-0.7 mm)
6. Concrete deck

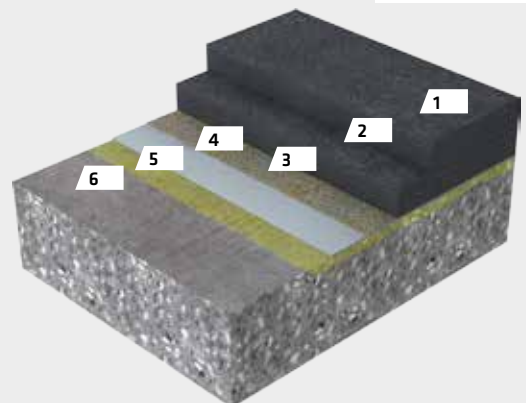





### 3 APPLICATION OF TACK COAT AND EXPANDABLE PELLETS

#### SIKA SOLUTIONS

New technology with Sikalastic® waterproofing membrane (e.g. Sikalastic®-851 / Sikalastic®-841 ST)

- Liquid applied membrane based on Polyurethane or Polyurea
- New innovative Sikalastic®-827 pellets-system for high bond and shear strength

#### SIKA'S ADVANCED SYSTEM

- Light-weight system
- Customized solution with Sika expert competence
- For new construction or refurbishment
- System build-up with different protection and bonding solutions
- ETAG 033 and BBA HAPAS certified
- Improved adhesion reduces maintenance costs & increases safety for vehicles
- Global technical support
- Rain tight in minutes

## SIKA PROTECTION SOLUTIONS FOR STEEL BRIDGE DECKS

#### Sikalastic®-8800 ONE SHOT SYSTEM

1. **Top coat:** Sikafloor® 359
  2. **Wearing coat:** Sikalastic®-8800 with aggregate injection
  3. **Waterproofing membrane:** Sikalastic®-8800
  4. **Primer:** SikaCor® Elastomastic Airless
  5. Steel deck
- System without asphalt topping
  - Directly trafficable
  - Very high mechanical and abrasion resistance
  - Excellent corrosion protection

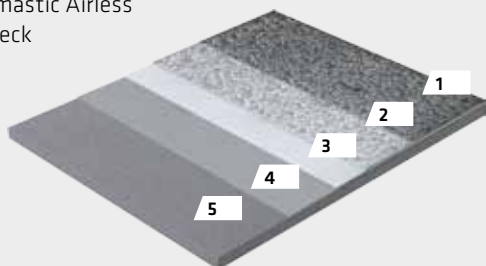

#### SikaCor® HM Mastic + Sikalastic®-827 / HT

1. **Wearing course:** Hot mixed asphalt / asphalt concrete (+140-180°C)
  2. **Base course:** mastic asphalt (+240°C), or hot mixed asphalt / asphalt concrete (+140-180°C)
  3. SikaCor® HM Mastic + Sikalastic®-827 / HT pellets broadcast
  4. **Primer:** 2-component-epoxy SikaCor® HM Primer
  5. Steel deck > 12 mm
- Thin layer corrosion protection
  - Good bonding and high shear strength to asphalt under different application temperatures

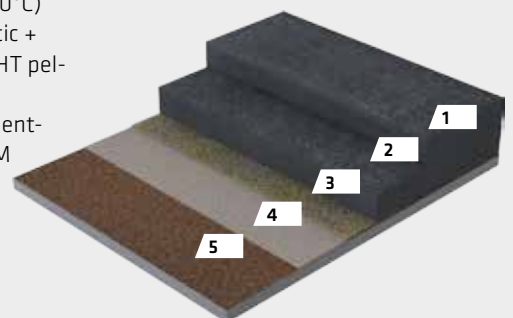

# SIKA SOLUTIONS FOR WATERPROOFING



## Sika Solutions for Bonding Asphalt Overlays

New innovative Sikalastic®-827 pellets bond asphalt overlays to Sika waterproofing systems by expanding and melting, forming a mechanical and chemical bond at the interface. This dramatically increases both shear and tensile bond strengths, thus increasing safety to heavy traffic braking and long term durability.

### Advantages:

- Increased shear and tensile bond strengths
- Increased safety
- Reduced long term maintenance costs
- Reduced life cycle costs
- Easy to apply
- Works with a wide asphalt temperature range



### Sika Solutions for Lightweight Wearing Surfaces

Waterproof, anti-slip systems for bridge decks:

- Epoxy-urethane system:  
System consisting of an appropriate substrate primer with Sika® Elastomastic® TF tough, elastic waterproof wearing layer. Approved & certified according to the German regulation for riveted and welded steel bridges, with or without ballast.
- Pure polyurea spray applied system:  
Fast curing pure polyurea membrane with aggregate injection system for pedestrian or cycle bridges consisting of a primer and Sikalastic® One Shot system waterproofing and wearing layer.
- Optional color stable top coats from the Sikafloor® range are suitable for both systems.



### Sika Solutions for Elastic Joint Sealing

High Performance watertight joint sealing systems for use on bridge decks, parapets and other elements:

- For facade and parapet joint waterproofing:  
Sikadur® Combiflex® SG system
- For bridge deck and deck waterproofing edge terminations:  
Sika® Dilatec® B, R and E edge systems
- For facade joint waterproofing:  
Sikaflex® joint sealants



### Sika Solutions for Waterproofing Cracks

Structural bonding and flexible watertight injection systems for crack sealing in concrete structures:

- For the surface sealing of bridge decks:  
Flexible polyurethane and acrylic resin based injection systems – Sika® Injection systems
- For structural cracks and void repair:  
Sikadur®-52 and Sika® Injection 451 low viscosity, epoxy resin based systems



# SIKA SOLUTIONS FOR CONCRETE PROTECTION

## Overview

To improve the performance and durability of reinforced concrete surfaces on bridge structures, additional protection systems are frequently required, particularly in refurbishment situations. Typical concrete protection systems for bridges can be classified as hydrophobic impregnations, sealing impregnations, surface coatings, or corrosion inhibitors. These are designed for use in different situations or collectively in alternative combinations, to greatly reduce damage to the concrete surfaces and to stop or significantly reduce the rate of steel reinforcement corrosion. Thus preventing the even more significant structural damage, that would otherwise occur.

## Requirements

- Protection against ingress of water, chloride and carbon dioxide
- High resistance against UV radiation
- Resistance against frost and wide temperature variations

## Sika in Concrete Protection

Sika provides a wide range of tested and well proven concrete protection systems based on different technologies including hydrophobic impregnations, impregnations, rigid and elastic surface coatings, galvanic anodes, and surface applied corrosion inhibitors. All of these Sika products and systems fully comply with various standards and regulations (when relevant).



## Added Value from Sika in Concrete Protection

### Durable and Invisible Protection for Fair-Faced Concrete

The unique and complete concrete protection system, consisting of Sika® FerroGard®-903 Plus corrosion inhibitor and Sikagard®-700 series hydrophobic impregnations

#### Advantages:

- No change in the structure's appearance
- Dual protection behavior – for steel reinforcement and concrete surfaces
- Cost effective solutions
- Fast and easy to apply



### Sika Solutions for Corrosion Mitigation

- Liquid, surface applied corrosion inhibitor:  
Sika® FerroGard®-903 Plus
- Galvanic protection systems:  
Sika® FerroGard® Galvanic anodes\*
- Deep penetrating hydrophobic impregnations  
Sikagard® -705 L/-706 Thixo

\*note: refer to local country for availability



### Sika Solutions for Fair Faced Concrete

Durable, deep penetrating, protective hydrophobic impregnations for facades, beams, columns and all areas of the bridge superstructure:

- Cream silane based product:  
Sikagard®-706 Thixo
- Liquid silane based product:  
Sikagard®-705 L



### Sika Solutions for Colored Concrete

Rigid, continuous film-forming, protective concrete surface coatings:

- High performance, solvent dispersed, acrylic resin coating  
Sikagard®-680 S BetonColor
- Water dispersed, protective acrylic resin coating:  
Sikagard®-675 W ElastoColor®
- Long term durable water-dispersed PU dispersion coating:  
Sikagard®-690 W HD



### Sika Solutions for Cracking Concrete

High build, film-forming protective concrete coating system with crack-bridging abilities:

- Water dispersed, high build, acrylic resin based, elastic intermediate and surface levelling coating:  
Sikagard®-545 W Elastofill®
- Water based, high build, elastic crack-bridging, colored, protective top-coating:  
Sikagard®-550 W Elastic



# SIKA SOLUTIONS FOR GROUTING AND FIXING

## Overview

Remedial works on concrete bridge structures often include the requirement for void filling, fixing and sealing or bedding and grouting with free flowing materials. Typical examples are concrete repairs using formwork, high precision grouting under bridge bearing plates, or for cable duct grouting. Additionally flowable resin and cement grouts are used to fix manholes or other steel frames and equipment, where rapid hardening materials are usually required to reduce closure times.

## Requirements

- High strengths and low creep under permanent load
- Low shrinkage and reduced tendency to cracking
- Excellent flow characteristics
- Easy handling and application
- Fast application and hardening

## Sika in Grouting and Fixing

Sika provides a wide range of tested and well proven grouts and fixing materials based on all of the different technologies available including cement, epoxy, polyurethane and PMMA. For many decades, Sika has also provided special products for high precision applications such as bearing plates, rail tracks and duct sealing.

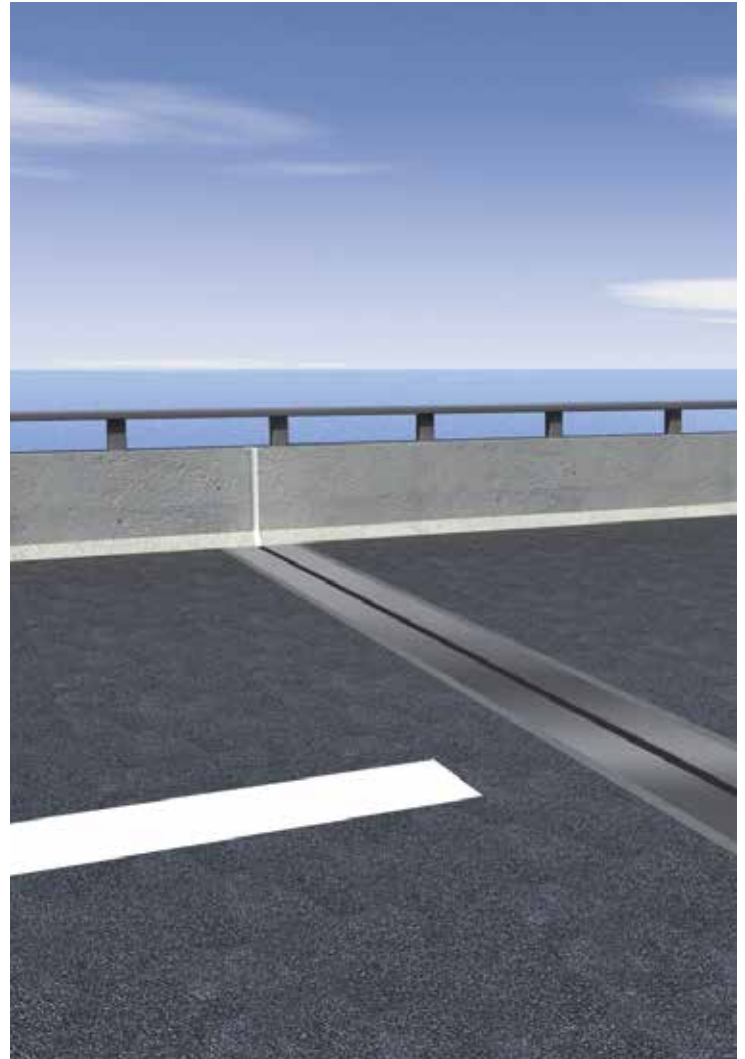

### Sika Solutions for Structural Grouting

Materials for grouting under bridge bearing plates and to fill voids, holes and cavities or for embedding drainage pipes and other elements:

- Cement based, high precision grouting products:  
SikaGrout®-300 series
- Epoxy resin based, rapid hardening, high strength grouting products for use under dynamic loading:  
Sikadur®-42 series
- PMMA resin based, grouting products for application at low temperatures down to -10 °C:  
Sikadur®-12 Pronto



### Sika Solutions for Fixing of Road Components

Sika® FastFix® systems for road construction and maintenance works:

- Fixing and bedding of manhole frames and mechanical joint hosing:  
Sika® FastFix®-138 TP or Sika® FastFix®-4
- Concrete kerb bedding and jointing:  
Sika® FastFix®-1 TP
- Block paviour and stone set pavement bedding and jointing:  
Sika® FastFix®-133 TP



### Sika Solutions for Rail Tracks

Rail fixing, damping and bedding solutions for all types of rail track systems to be installed on bridge decks:

- Discrete fixing solutions  
Icosit® KC range
- Direct rail track fixing and bedding solutions:  
Icosit® KC range



# SIKA SOLUTIONS FOR STEEL CORROSION PROTECTION

## Overview

Structural steel is widely used around the world for the construction of bridges and bridge components including the superstructure, parapet railings, decks and cables. The corrosion protection of this steel is essential to increase the durability and sustainability of the structure. Chlorides and condensed water can accelerate the steel corrosion process and must be kept away from the steel surfaces.

## Requirements

- Corrosion protection in accordance with EN ISO 12944
- UV and weathering resistance
- Coating system service life of 20 - 25 years to reduce maintenance / closures
- Fulfil high aesthetic demands in appearance
- Low VOC emissions
- Fast curing / short inter-coat waiting times
- Elastic behaviour (systems for steel cable protection particularly)

## Sika in Steel Corrosion Protection

Sika provides a wide range of tested and approved steel protection systems based on the latest technologies and our long-term experience with steel coatings. Sika produces the most advanced protective coating systems for bridges, designed to be selected in accordance with international standard EN ISO 12944, which ensures the defined service life to the first maintenance and the sustainability is assured.





### Sika Solutions for Shop Application

Steel corrosion protection systems with fast curing 2-component epoxy and polyurethane resin based coatings. Designed for shop application with the 3 layer application system build-up possible in a single day:

- High-performance and long-term steel corrosion protection with the SikaCor® EG -Rapid System
- Tested and approved in accordance with TL/TP-KOR page 97 and EN ISO 12944 part 5



### Sika Solutions for Maintaining Existing Coatings

Protective coating systems for steel maintenance, designed for application on site. Specifically formulated for use on non-blast cleaned surfaces, suitable for use on steel surfaces that are site prepared mechanically with power tools:

- Sika® Poxicolor® Primer HE NEU followed by SikaCor® EG 120
- Tested and approved in accordance with EN ISO 12944 part 5



### Sika Solution for Protecting Steel Bridge Cables

A unique protective coating system, especially designed for the protection of structural steel cables on cable-stayed bridge structures. The system includes flexible coatings and injection products for corrosion protection in steel cable anchors and connectors:

- Sika® Cable System
- Tested and approved in accordance with German Standard TL/TP-KOR "Seile"



# SIKA SOLUTIONS FOR STRUCTURAL BONDING

## Overview

Structural adhesives are used for many bonding applications in new construction and refurbishment. The bond must allow the transfer of high loads without deformation and creep. The main function of structural adhesives is in the bonding of similar or dissimilar materials together (i.e. concrete to steel, steel to composites etc). Dependent on their design, structural adhesives can not only bond the elements together, but they can also fulfil additional functions such as waterproofing, sealing, concrete protection or even vibration dampening.

## Requirements

- Good creep resistance
- Uniform and direct load transmission
- Resistant and able to accommodate dynamic loading
- Good aging resistance

## Sika in Structural Bonding

Sika has been a pioneer in the use of resin adhesives for structural bonding of precast concrete elements since the 1960's. Sika's epoxy adhesives have now been used to bond segmental bridge structures all around the world. This extensive experience has allowed the development of a wide range of additional structural bonding products and systems for unique applications. In the 1990's Sika also introduced a complete range of cartridge applied resin anchoring adhesives for many different applications.



## Added Value from Sika in Structural Bonding

### Structural Bonding of Ultra High Performance Concrete (UHPC)

Sikadur®-30 epoxy adhesive for the structural bonding of Ultra High Performance Concrete (UHPC) precast elements

#### Advantages:

- High mechanical strengths
- Excellent creep behavior – confirmed by longterm testing
- No shrinkage
- High durability, even at high temperatures and high humidity
- Resistant to freeze/thaw exposure
- High fatigue resistance under dynamic load
- High abrasion, shock and impact resistance
- Good chemical resistance (including to oils and de-icing salts etc.)



### Sika Solutions for Rigid Structural Bonding

Epoxy adhesives for bonding different elements or components to concrete, steel or bituminous substrate:

- Sikadur®-30 for high-performance bonding of steel plates on to concrete
- Sikadur®-31 CF for multi-purpose bonding such as precast concrete or natural stone kerbs onto concrete or asphalt surfaces



### Sika Solutions for Structural Anchoring

Special structural adhesives for anchoring all types of fittings and equipment to bridge structures such as for the installation of cable trays or other services, crash barriers, drainage pipes, inspection access equipment, catch nets, etc.:

- ETAG approved, structural resin anchoring adhesive Sika® AnchorFix®-2, for the installation of threaded rods and steel dowel bars at temperatures as low as -5 °C.
- High performance, epoxy resin based, anchoring adhesive Sika® AnchorFix®-3+, for secure structural installations, even into damp substrates



### Sika Solutions for Steel Fixtures and Fittings

Special epoxy mortars for the bedding, bonding and dry-packing of many different types of fixtures and fittings, including steel frames and parapet railings, etc.:

- 3-component, non-shrink, epoxy resin based mortars Sikadur®-41 CF and Sikadur®-43 HE



# SIKA SOLUTIONS FOR SEGMENTAL BRIDGE ADHESIVE

## Overview

Segmental bridges are built in short sections (called segments) one piece at a time, whereby traditional methods build a bridge in very large sections. Segmental bridges are made of precast concrete, which is manufactured at another location and then transported to the final location for placement within the complete structure. They are very economical for long spans (over 100 meters), especially when access to the construction site is restricted, and also allow for special design features to enhance the beauty of the structure.

## Dry joints versus wet joints

Dry joints are created when the concrete segments are formed by match casting, which requires more precise mould dimensions. Such joints can be economical due to lower cost and time required for construction.

When placed on site, the joint is not sealed, and therefore leakage into the box culvert is often an issue with this type of construction possibly affecting durability in the future.

Wet joints require the use of an epoxy adhesive placed in the joint. This epoxy also helps lubricate the joint to facilitate installation during construction, provides load transfer during pre-stressing and prevents any water ingress through the joint, enhancing the long-term durability of the bridge.

This wet joint technique was first used in Switzerland in the late 1960's at the Viaduct de Chillon using Sikadur epoxy adhesive.



### Sikadur-31 SBA

Range of thixotropic, structural two part adhesive especially formulated for segmental bridge construction; available in different grades to suit different applications and environmental conditions.

All grades present advantages such as the following:

- Meets and/or exceeds internal and national standards (FIP, BS, AASHTO, ASTM, etc.)
- High strength and high modulus of elasticity
- Impermeable of liquid and water vapor
- No primer required



### Application temperature range of Sika's SBA Adhesives

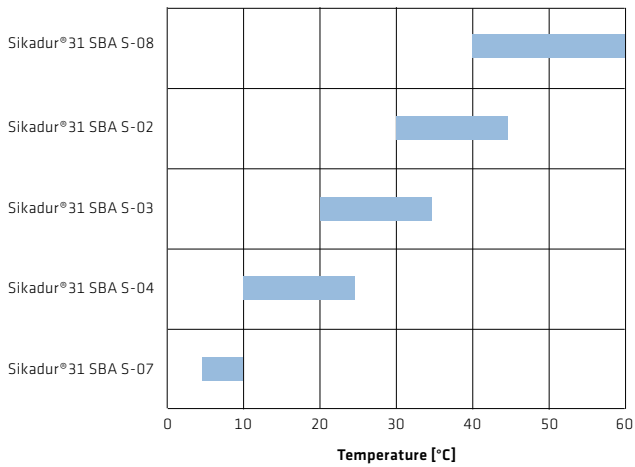

# SIKA SOLUTIONS FOR THE REHABILITATION OF MASONRY OR WOODEN BRIDGES

## Overview

Generally, wooden or masonry bridges are old structures and may suffer from decays over the ages, which is most often due to a lack of deck waterproofing or other structural component failure. On some occasions, the design load no longer complies with new traffic regulations.

## Requirements

- Protection against water ingress
- Structural strengthening
- Invisible solution in order to maintain the appearance of old, historical or iconic structures

## Sika in rehabilitation of masonry or wooden bridges

Sika, as a specialist in waterproofing, masonry protection and structural strengthening, offers a full range of systems to prevent water ingress and to increase the structural capacity of these old structures.

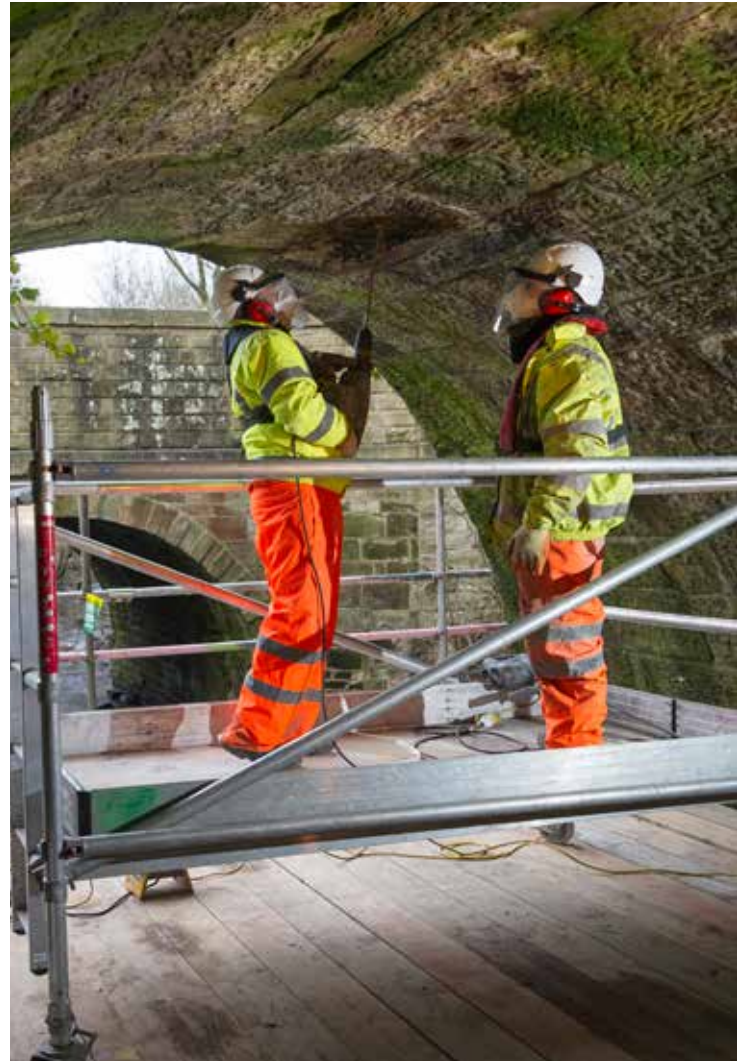

### Sika Solutions for Masonry Protection

Old structures shall retain their visual appearance and any treatment shall not affect the breathing capacity of the structures.

- Liquid siloxane emulsion Sikagard®-703 W
- High performance cream siloxane Sikagard®-730 Thixo



### Sika Solutions for Structural Strengthening

Functionality and durability of bridges can be improved by structural strengthening, while still keeping the outward appearance of the structure.

- Externally bonded or near surface mounted Sika CarboDur® CFRP strengthening system
- Textile reinforced mortar for masonry strengthening



### Sika Solutions for Crack Injection

The durability of masonry bridges can be improved by injections:

- Sika InjectoCem®-190 for filling the joint
- Sika Injection®-304 for rising damp treatment

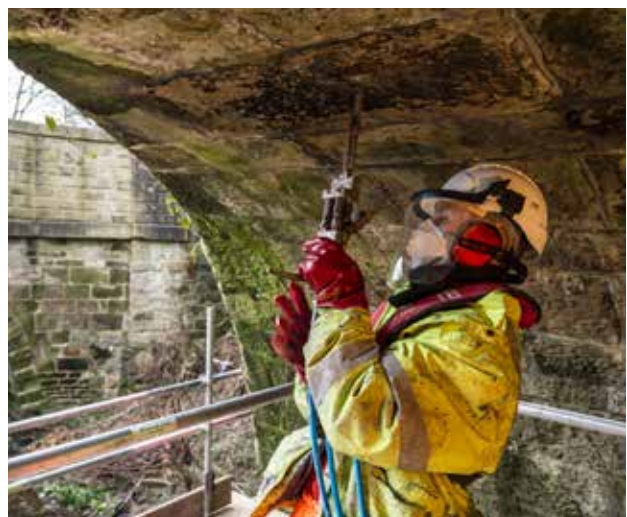

# ALSO AVAILABLE FROM SIKA

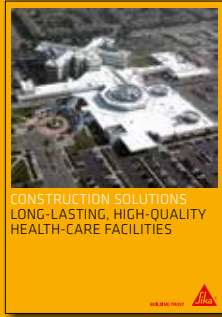

## FOR MORE FULL RANGE SOLUTION INFORMATION:



### WE ARE SIKA

Sika is a specialty chemicals company with a leading position in the development and production of systems and products for bonding, sealing, damping, reinforcing and protecting in the building sector and the motor vehicle industry. Sika's product lines feature concrete admixtures, mortars, sealants and adhesives, structural strengthening systems, industrial flooring as well as roofing and waterproofing systems.

Our most current General Sales Conditions shall apply. Please consult the most current local Product Data Sheet prior to any use.



**SIKA SERVICES AG**  
Tueffenwies 16  
CH-8048 Zurich  
Switzerland

**Contact**  
Phone +41 58 436 40 40  
Fax +41 58 436 41 50  
www.sika.com

**BUILDING TRUST**

